

HYCOM DATASHEET

GROUND CHECK MOTOR FOR AIRCRAFT MAINTENANCE
MODEL HRT

IDEAL FOR

FUNCTIONAL TEST OF RAM AIR TURBINE AS PER AMM

MODEL

HRT-05

SUITABLE FOR

Airbus A350 XWB

BENEFITS

- Certified by Airbus
- Easy to install
- Simple to operate
- Light weight

FEATURES

Certified and listed in Airbus Tool / Equipment Bulletin

- High performance hydraulic motor
- Handgrip for easy handling of the tool
- Flange protector to prevent scratches to the aircraft ram air turbine
- Internal flushing and cooling of the hydraulic motor
- The ram air turbine of the aircraft will not be damaged in case of shaft seal failure of the hydraulic motor
- Unique integrated feature to prevent cavitation of the hydraulic motor in case of emergency stop
- Tool connects directly to the quick disconnect couplings of the hydraulic test stand
- Heavy duty case with retractable extension handle and wheels

TECHNICAL DATA

REQUIREMENTS FOR HYDRAULIC TEST STAND

Fluid	Phosphate-Ester based fluids e.g. Skydrol or Hyjet
Pressure	5000 PSI (350 bar)
Flow	50 USgpm (190 l/min)
Quick disconnect couplings	Hycom HQD-030-HA

DIMENSIONS & WEIGHT

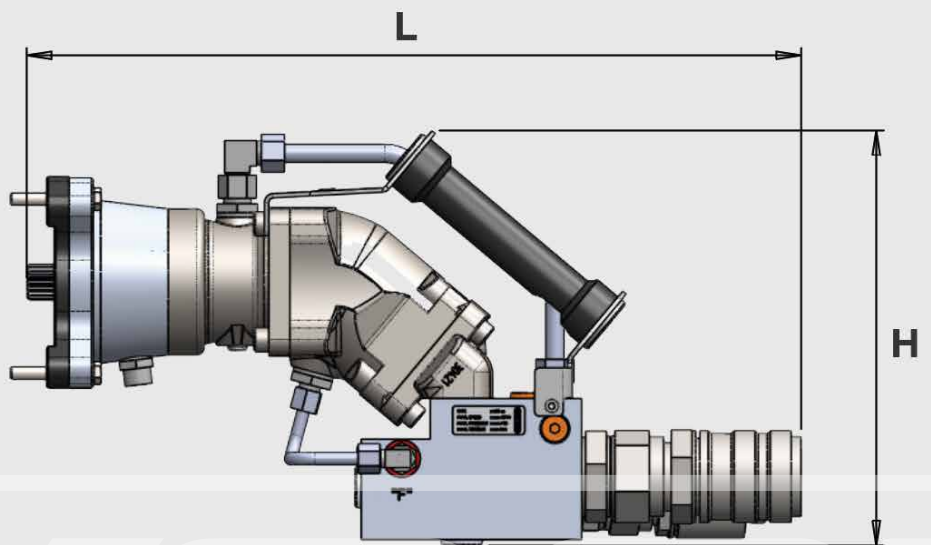
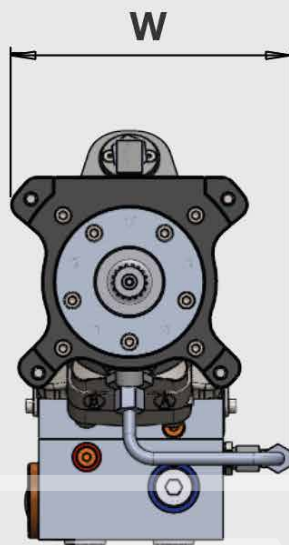
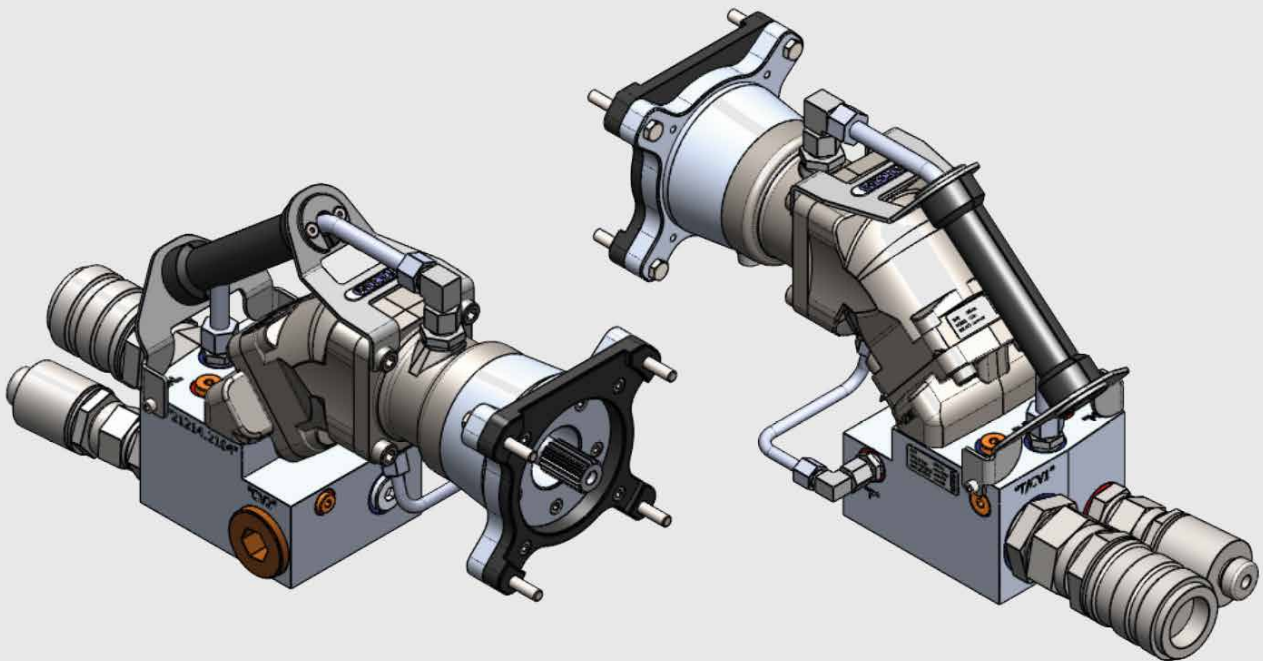

MOTOR

LENGTH	520 mm
WIDTH	190 mm
HEIGHT	280 mm
WEIGHT	approx. 19 kg

INCLUDING CASE

LENGTH	690 mm
WIDTH	530 mm
HEIGHT	480 mm
WEIGHT	approx. 32 kg

IMAGES





HYCOM B.V.

P.O. BOX 1079 | 7301 BH APELDOORN
ANTILLEN 43 | 7333 PE APELDOORN

T +31 88 0597 200

E INFO@HYCOM.NL | W WWW.HYCOM.NL