



HYCOM DATASHEET

HYDRAULIC HOSE TEST BENCH
MODEL HTB electric driven

IDEAL FOR

PRESSURE TESTING OF HYDRAULIC HOSES AND PIPING UP TO 700 BARS

MODEL

HTB – 5 – 700 – E/1 – ●

VERSION

DETERMINED BY HYCOM

FEATURES

- Stainless steel reservoir of 30 liter with filler breather cap, level gauge and drain valve
- Radial piston pump for reliable and low noise operation
- Internal flushing valve

- Operator panel with clear layout
- Pressure adjustment by turning knob
- Lights for running, general failure, low oil level, oil temperature and clogged filters

- Heavy duty stainless steel frame with rigid and caster wheels
- Test cubicle with safety glass
- Reel for storing electric cable and hydraulic hoses
- Doors for easy maintenance

- Hydraulic and electric components completely isolated from each other
- Automatic shut down in case of low oil level and high oil temperature
- Phase sequence relay
- Emergency stop button



OPERATOR PANEL



- A Status indicators
- B Supply pressure gauge
- C Test pressure gauge
- D Pressure adjustment knob

HYCOM

TECHNICAL DATA

GENERAL

Main power supply cable	10 meter
Noise level	less than 75 dbA at 1 meter distance

HYDRAULIC

Mineral based e.g. MIL-PRF-5606 or Phosphate ester based e.g. Skydrol or Hyjet
Approx. 5 l/min at 0 – 10,150 psi

Supply (3 micron) and return (10 micron) filters with electric clogging indicators

MEASUREMENT

Supply pressure gauge	0-12,000 psi Accuracy 1,0% of full scale
-----------------------	---

Test pressure gauge	0 – 12,000 psi Accuracy 1,0% of full scale
---------------------	---

POWER

Supply	3 Ph. 380/420 V – 50 Hz, other on request
Current	32 A – 50 Hz
Electric motor	11 kW – 50 Hz

DIMENSIONS & WEIGHT

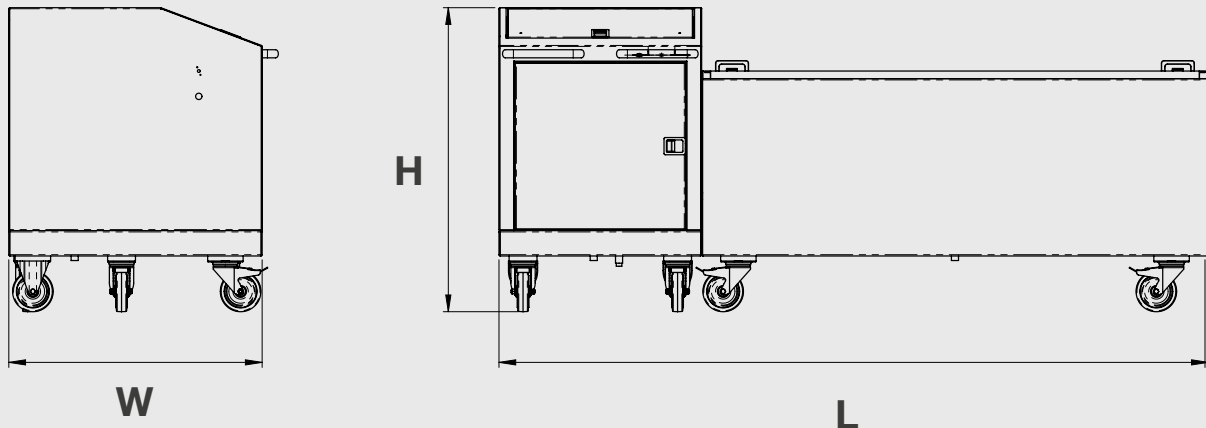

LENGTH	2800 mm
WIDTH	1000 mm
HEIGHT	1200 mm
WEIGHT	approx. 350 kg

OPTIONS AND ACCESSORIES

Hoses and adapters to connect test bench to UUT (Unit Under Test)

Plug for electrical connection

Suitable for mineral based fluids

Other options and accessories are available upon request

IMAGES





HYCOM B.V.

P.O. BOX 1079 | 7301 BH APELDOORN
ANTILLEN 43 | 7333 PE APELDOORN

T +31 88 0597 200

E INFO@HYCOM.NL | W WWW.HYCOM.NL