



HYCOM DATASHEET

MOBILE HYDRAULIC TEST STAND FOR AIRCRAFT MAINTENANCE
HTM diesel driven

IDEAL FOR

- MAINTENANCE AND OVERHAUL CHECKS OF AMM / ATA CHAPTER 29
- FILLING AND DRAINING OF AIRCRAFT RESER VOIR
- FLUSHING OF AIRCRAFT HYDRAULIC SYSTEM TO CLASS 6 NAS1638 OR BETTER

MODEL

HTM - ● - F - ■

FLOW RANGE

● = 4 : 0-4 USGPM PER SYSTEM

PURIFIER

■ = S : SINGLE SYSTEM

FEATURES

- Single with one pressure and one return line
- Axial piston pump variable stroke with proportional control of flow and pressure
- Boost pumps for closed loop circuit
- Stainless steel reservoir of 40 liter with drain valve and filling cap
- Fluid contamination level NAS 1638 class 6 or better
- Oil-air cooler with low noise level suitable for tropical conditions
- Open and closed loop configuration for filling and draining of A/C reservoir
- Temperature and boost pressure shut down switches
- Oil sample and calibration points
- De-aeration / flushing valve
- Operator panel with graphic layout, digital display with maintenance and failure indication given in clear text
- Controlled by a PLC system with safety devices and switches
- Flow setting by potentiometer. Display will indicate the value of actual flow
- Pressure setting by push buttons + and –
- 3000 psi pre-selection push button
- Hydraulic and electric components completely isolated from each other
- Weather proof cover for operator panel
- Canopy out of steel, spray painted
- Doors for easy maintenance
- Heavy duty frame with drip tray
- Lifting points, tie down and fork lift pick-up points
- Maximum towing speed 16 km/h
- Parking brake on front wheels by tow bar in upright position

OPERATOR PANEL



- A Digital display with failure and maintenance notifications
- B Digital readout of actual flow
- C High and return pressure gauges



TECHNICAL DATA

GENERAL

Hydraulic hoses: 6 meter
Noise level: less than 82 dbA at 2 meter distance

HYDRAULIC

300-3000 psi at 8 USGPM each system, 3500 psi at reduced flow

High (3 micron) and low pressure (10 micron) filters with electric clogging indicators

MEASUREMENT

High pressure gauge 0-4000 psi
Accuracy 1% of full scale

Return pressure gauge 0-200 psi
Accuracy 1% of full scale

Digital readout of actual flow

POWER

Engine Single cylinder, Stage V
Power 7,1 kW at 2000 rpm



DIMENSIONS & WEIGHT

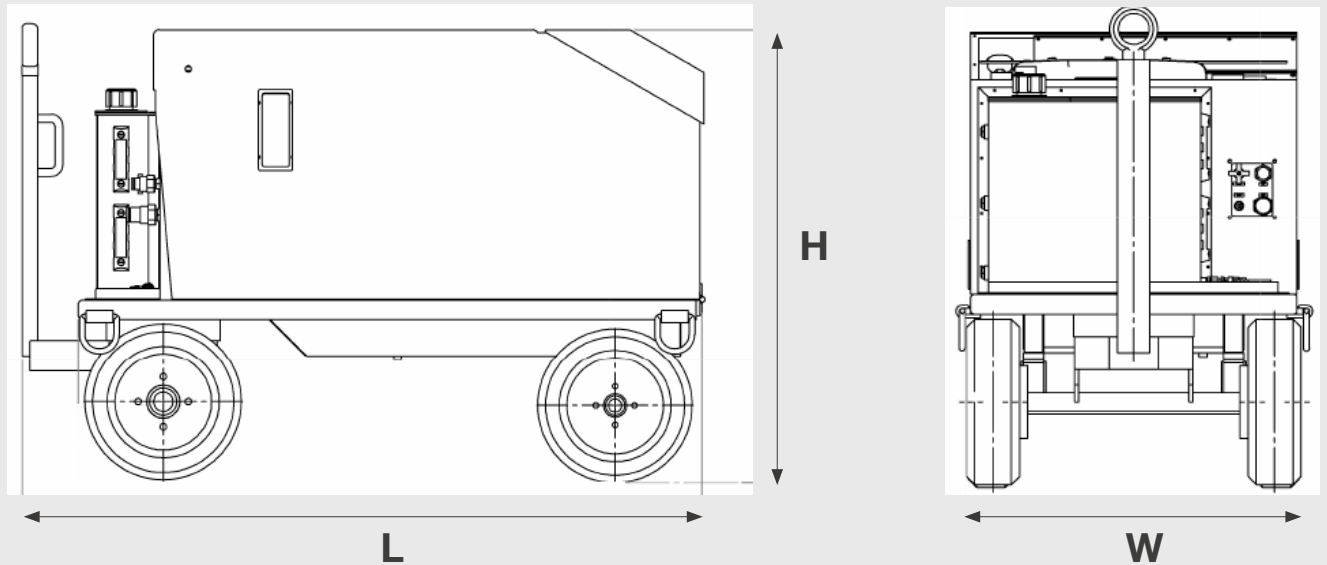

LENGTH	1760 mm
WIDTH	860 mm
HEIGHT	1180 mm
WEIGHT	approx. 600 kg

POSSIBLE OPTIONS

Z = Quick disconnect couplings to connect hoses to the aircraft

Other options and accessories are available upon request.

IMAGES





HYCOM B.V.

P.O. BOX 1079 | 7301 BH APELDOORN
ANTILLEN 43 | 7333 PE APELDOORN

T +31 88 0597 200

E INFO@HYCOM.NL | **W** WWW.HYCOM.NL