



HYCOM DATASHEET

HYDRAULIC FLUID PURIFIER FOR AIRCRAFT MAINTENANCE
MODEL HFP

IDEAL FOR

DEWATERING, FILTERING AND DEGASSING OF HYDRAULIC FLUIDS

MODEL

HFP - 04 - E/1 - ● - ■

FLUID

- = M : MINERAL BASED
- = P : PHOSPHATE ESTER BASED

READOUT

- = N : NAS 1638
- = I : ISO 4406:1999

FEATURES

- Purification of aircraft hydraulic system during maintenance tasks
- Different operation modes:
 - Purification of aircraft hydraulic system, connected to hydraulic test stand and aircraft
 - Purification of hydraulic test stand
 - Purification of internal reservoir purifier
 - Filling and draining of aircraft reservoir
 - Filling and draining of hydraulic test stand reservoir
 - Transferring oil from barrel to internal reservoir purifier
- Removal of water to less than 100 ppm
- Removal of 100% free and 95% dissolved gases
- Integrated heaters to increase dewatering capacity
- Fluid contamination level NAS 1638 class 3 or better
- Operator panel with large touchscreen for easy operation
- Different interface languages integrated e.g. English, German, Dutch, French and Chinese
- Controlled by a PLC system with safety devices and switches
- Automatic shutdown in case of over pressure
- Integrated data recorder
- Connectivity for condition monitoring via computer and smartphone
- Stainless steel reservoir 250 liter with drain valve and filler cap
- Gear pumps for reliable operation
- Plate heat exchanger for improved performance and energy recovery
- Oil sample point and calibration points
- Hydraulic and electric components completely isolated from each other
- Weather proof cover for operator panel
- Canopy out of stainless steel
- Doors for easy maintenance
- Heavy duty frame with drip tray
- Towbar with steering axle
- Parking brake on front wheels by tow bar in upright position
- Lifting points, tie down and fork lift pick-up points

FEATURES



- A Large touchscreen for easy operation
- B Emergency button
- C Connection for condition monitoring with computer

HYCOM

TECHNICAL DATA

GENERAL

Main power supply cable: 20 meter
Hydraulic hose to connect to A/C: 6 meter

HYDRAULIC

Maximum inlet flow 60 USgpm (227 l/min)
Internal pump flow 15 l/min

Fluid -M: Mineral based e.g. MIL-H-5606, MIL-H-83282 or MIL-H-87257
-P: Phosphate ester based e.g. Skydrol or Hyjet

High flow (3 micron) and low flow (1 micron) filters with electric clogging indicators

MEASUREMENT

Digital readout of Cleanliness class according to NAS 1638
Water saturation in %
Fluid temperature

POWER

Supply 3 Ph. 380/420 V – 50 Hz, other on request
Current 63 A – 50 Hz

DIMENSIONS & WEIGHT

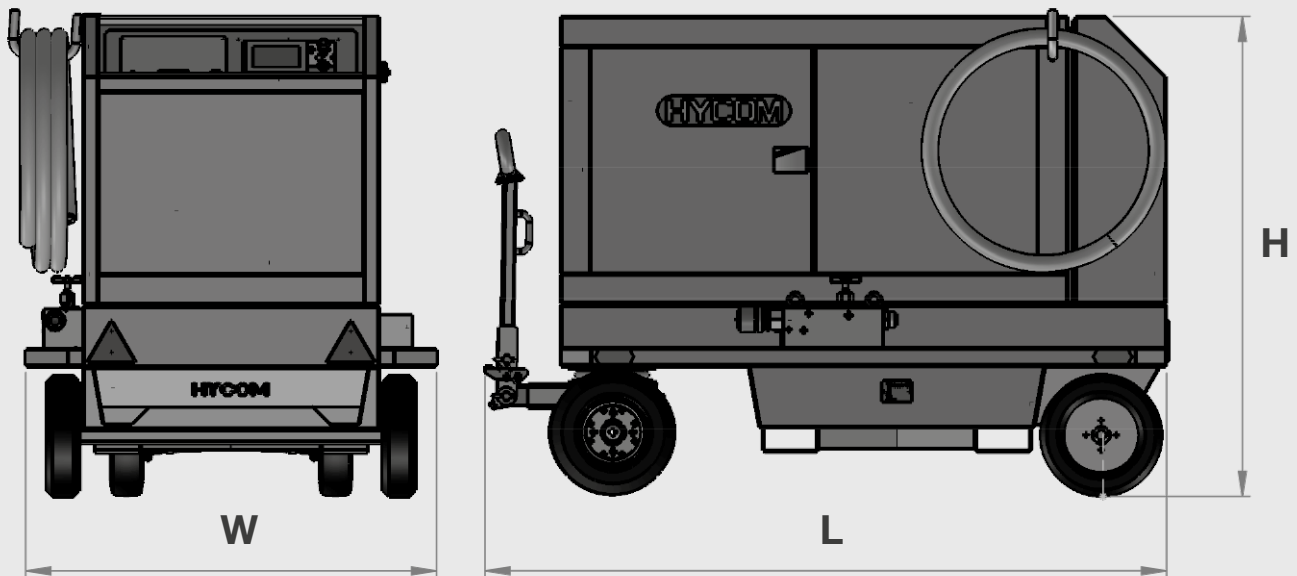

LENGTH	226 cm
WIDTH	145 cm
HEIGHT	160 cm
WEIGHT	approx. 1100 kg

POSSIBLE OPTIONS

Z: Quick disconnect couplings to connect the equipment to the aircraft and hydraulic test stand

Other options and accessories are available upon request.

IMAGES



HYCOM



HYCOM B.V.

P.O. BOX 1079 | 7301 BH APELDOORN
ANTILLEN 43 | 7333 PE APELDOORN

T +31 88 0597 200

E INFO@HYCOM.NL | W WWW.HYCOM.NL